

7. How to Contact ProAVM

For all enquiries write to:-

ProAVM
61 Station Road
Irthlingborough
Northants
NN9 5QE
United Kingdom

Or telephone 01933 650 700 within the UK, +44 1933 650 700 from outside the UK.

Or fax 01933 650 726 within the UK, +44 1933 650 726 from outside the UK.

Or email sales@proavm.com for sales enquiries or technical.support@proavm.com for technical support.

Alternatively visit our web site: <http://www.proavm.com>

8. Declaration of Conformity

Name of Manufacturer: ProAVM
Address of Manufacturer: 61 Station Road
Irthlingborough
Northants
NN9 5QE

Product: DA-ITR4x16 4 Input, 16 Output Versatile Matrix Routing Distribution Amplifier, Rackmount

Declaration: The product described above complies with the requirements of the Low Voltage Directive (73/23/EEC) and the protection requirements of the EMC Directive (89/336/EEC) issued by the Commission of the European Community.

Compliance with these directives implies conformity to the following European Standards:

EN 60065:1993	Safety requirements for mains operated electronic and related apparatus for household and similar general use
EN 55103-1:1997	Electromagnetic compatibility - Product family standard for audio, video, audiovisual and entertainment lighting control apparatus for professional use (emissions - environmental categories E1 to E5)
EN 55103-2:1997	Electromagnetic compatibility - Product family standard for audio, video, audiovisual and entertainment lighting control apparatus for professional use (immunity - environmental categories E1 to E5)

9. Warranty

This product is shipped with a 5 year return to base warranty. Please return the product to the company that you bought it from.

No part of this manual may be reproduced or transmitted in any form or by any means, electronic or mechanical, including photocopying, recording or information storage and retrieval systems, for any purpose other than the purchaser's personal use, without the express written permission of ProAVM.

Information in this document is subject to change without notice and does not represent a commitment on the part of ProAVM. ProAVM shall not be liable for any direct, indirect, consequential or incidental damages as a result of the use or misuse of this equipment, handbook or any related materials.



DA-ITR4x16 4 Input, 16 Output Versatile Matrix Routing Distribution Amplifier, Rackmount

V1.00 © ProAVM 2006

1. Introduction

The ProAVM DA-ITR4x16 is a versatile, user-configurable distribution amplifier combining four inputs, sixteen outputs and a flexible routing system in a 1U high package. Each output may be assigned to follow any of the inputs or one of two internal mix busses which carry a user-defined combination of the input signals.

Standard configurations as well as more unusual situations are therefore handled with ease. The extra pair of inputs allows dual stereo operation with the additional advantage that the user can choose exactly how many outputs are assigned to each source. The electronically balanced inputs and outputs may be individually unbalanced, with each output totally unaffected by the settings or load on any other. Inputs have individual front panel gain controls, and drive "audio present" indicators for at-a-glance monitoring of signal status.

The DA-ITR4x16 is packaged in a novel 1U case with moveable rack ears which allow the unit to be mounted with the connectors facing either direction within a 19 inch rack; alternatively, the ears may be rotated through 90 degrees for screw-down or screw-under mounting.

2. Safety & Electrical Hazard

This unit contains high voltages which could be fatal. YOU MUST ALWAYS ISOLATE THE UNIT FROM THE MAINS SUPPLY BY COMPLETELY DISCONNECTING IT BEFORE ATTEMPTING TO OPEN THE CASE.

THIS EQUIPMENT MUST BE EARTHED.

Do not expose this equipment to rain or any other source of water.

In common with all mains operated equipment, only suitably trained competent personnel should attempt to adjust, modify or repair this equipment or operate it with the cover removed. In case of query please contact your local agent or ProAVM. Any unauthorised adjustment, modification or repair of this equipment may invalidate any warranty and/or safety approvals that apply.

Please read all of this manual and familiarise yourself with the controls before attempting to use this equipment. To ensure safety, it is the responsibility of the user to install and operate this equipment in a manner that is within the manufacturers specifications.

3. Unpacking The Equipment

This package should contain, in addition to this manual:

1 x	DA-ITR4x16
1 x	IEC Mains lead

If any items are missing or damaged please inform your supplier immediately.

Ensure that the DA-ITR4x16 has been supplied for the correct mains/line voltage for your country.

4. Controls and Connectors

Inputs A, B, C, D	3 pin female XLR, electronically balanced. Inputs may be unbalanced without affecting gain by linking cold pin to ground inside the mating connector. Pin 1 Ground Pin 2 Hot (Phase) Pin 3 Cold (Non-phase)
Input Gain	Individual multiturn adjustments for channel gain. Gain range -25 to +10dB.
Outputs	2 x 25 way D-type plug (male), electronically balanced. Outputs may be individually unbalanced without affecting gain by linking cold/antiphase to ground inside the mating connector. Output 1/9: Hot (Phase) = Pin 1 Cold (Non-phase) = Pin 2 Ground = Pin 14 Output 2/10: Hot (Phase) = Pin 15 Cold (Non-phase) = Pin 16 Ground = Pin 3 Output 3/11: Hot (Phase) = Pin 4 Cold (Non-phase) = Pin 5 Ground = Pin 17 Output 4/12: Hot (Phase) = Pin 18 Cold (Non-phase) = Pin 19 Ground = Pin 6 Output 5/13: Hot (Phase) = Pin 7 Cold (Non-phase) = Pin 8 Ground = Pin 20 Output 6/14: Hot (Phase) = Pin 21 Cold (Non-phase) = Pin 22 Ground = Pin 9 Output 7/15: Hot (Phase) = Pin 10 Cold (Non-phase) = Pin 11 Ground = Pin 23 Output 8/16: Hot (Phase) = Pin 24 Cold (Non-phase) = Pin 25 Ground = Pin 12
Signal LEDs:	Illuminate in the presence of a signal level greater than -17dBu (after gain).
Power LED	Lights continuously to confirm correct operation of power supply.
Mains Fuse	20mm antisurge mains fuse. 250mA(T) for 230V units 500mA(T) for 115V units DISCONNECT MAINS BEFORE ATTEMPTING TO CHANGE FUSE.
Mains	IEC male connector.
Internal Option Links	Selectable input impedance. Assign internal mix busses. Output source selectors.

5. Operation

Refer to section 4 for a description of the controls and connectors.

Internal Option Links

The DA-ITR4x16 is normally shipped as a dual stereo distribution amplifier with four outputs assigned to each of the four inputs (see below). It is possible to select many other modes of operation through the configuration of clearly marked internal links.

To adjust the links first disconnect mains power from the unit, then remove the ten lid screws and the lid itself. Referring to both the information below and the enclosed block diagram, arrange the links into the positions corresponding to the desired configuration. Replace and secure the lid before reapplying power. Space is provided on the block diagram sheet for personal settings to be recorded.

Input Impedance

Four links, labelled "CH.A"..."CH.D", select the input impedance of inputs A through D respectively. The two settings available are 20kS (default - position marked "20K") and 600S (position marked "600R").

Mix Bus Selectors

Two blocks of links, labelled "MIX1" and "MIX2", allow any or all of the four inputs to be added to the two internal mix busses. Each block accepts up to four pairs of jumpers (labelled A to D), one for each of the inputs. Fitting a pair of jumpers feeds the corresponding input signal to the mix bus. As further

signals are added to the mix busses, the gain is automatically reduced to maintain headroom - i.e. if the input levels (after any input gain is applied) are all 0dBu, the level on the mix bus will be 0dBu regardless of whether one, two, three or four signals are routed to it. For correct operation it is important that jumpers are only fitted in pairs.

Default configuration is inputs A and B fed to MIX1 and inputs C and D fed to MIX2, but sufficient jumpers are supplied for any configuration.

Output Source Selectors

Sixteen blocks of links, labelled "O/P1"..."O/P16". On each block, a single jumper placed in one of the six marked positions assigns the corresponding output to follow either one of the four input signals (positions A, B, C or D) or one of the two internal mix busses (positions MIX1 or MIX2). For correct operation it is essential that only one jumper is fitted to each block.

Default configuration: Outputs 1, 3, 5 and 7 assigned to input A
 Outputs 2, 4, 6 and 8 assigned to input B
 Outputs 9, 11, 13 and 15 assigned to input C
 Outputs 10, 12, 14 and 16 assigned to input D

Connections

Inputs

Refer to section 4 of this manual for the pin connections of the female XLR sockets. For unbalanced use, link cold/antiphase (pin 3) to ground (pin 1) inside the mating connector and apply the signal between hot/phase (pin 2) and ground. To achieve specified performance, leads should be of quality screened cable and not exceed 10m in length

Outputs

Refer to section 4 of this manual for the pin connections of the male D-type plugs. For unbalanced use, link the cold/non-phase pin to the corresponding ground pin inside the mating connector and take the unbalanced signal between the hot/phase pin and ground. To achieve specified performance, leads should be of quality screened cable.

Input Gain Adjustment

Apply the expected input signal level to the DA-ITR4x16. Monitor the output and adjust the gain control (clockwise to increase gain) to give the level required. The signal present LEDs illuminate when a signal level greater than -17dBu (after gain has been applied) is present.

6. Specifications

Inputs	Electronically balanced, 20kohm or 600ohm input impedance
Maximum input level	+26dBu
Input CMRR	-60dB typical
Outputs	Electronically balanced
Maximum output level	+26dBu (into 10kohm), +25.5dBu (into 600ohm)
Nominal gain range	-25dB to +10dB
Noise	< -90dB (RMS, 20Hz-22kHz, 0dB gain)
Harmonic distortion	< 0.01% (100Hz-10kHz)
Interchannel crosstalk	< -80dB (1kHz, 0dB gain)
AF response	±0.1dB (20Hz-20kHz)
Power supply	115 or 230V AC
Power consumption	24VA
Dimensions	483mm x 145mm x 44mm
Weight	1.7kg unpacked, 1.9kg packed

ProAVM DA-ITR4x16

Internal Architecture and Configuration Record

SHADED AREA INDICATES DEFAULT POSITION OF LINKS

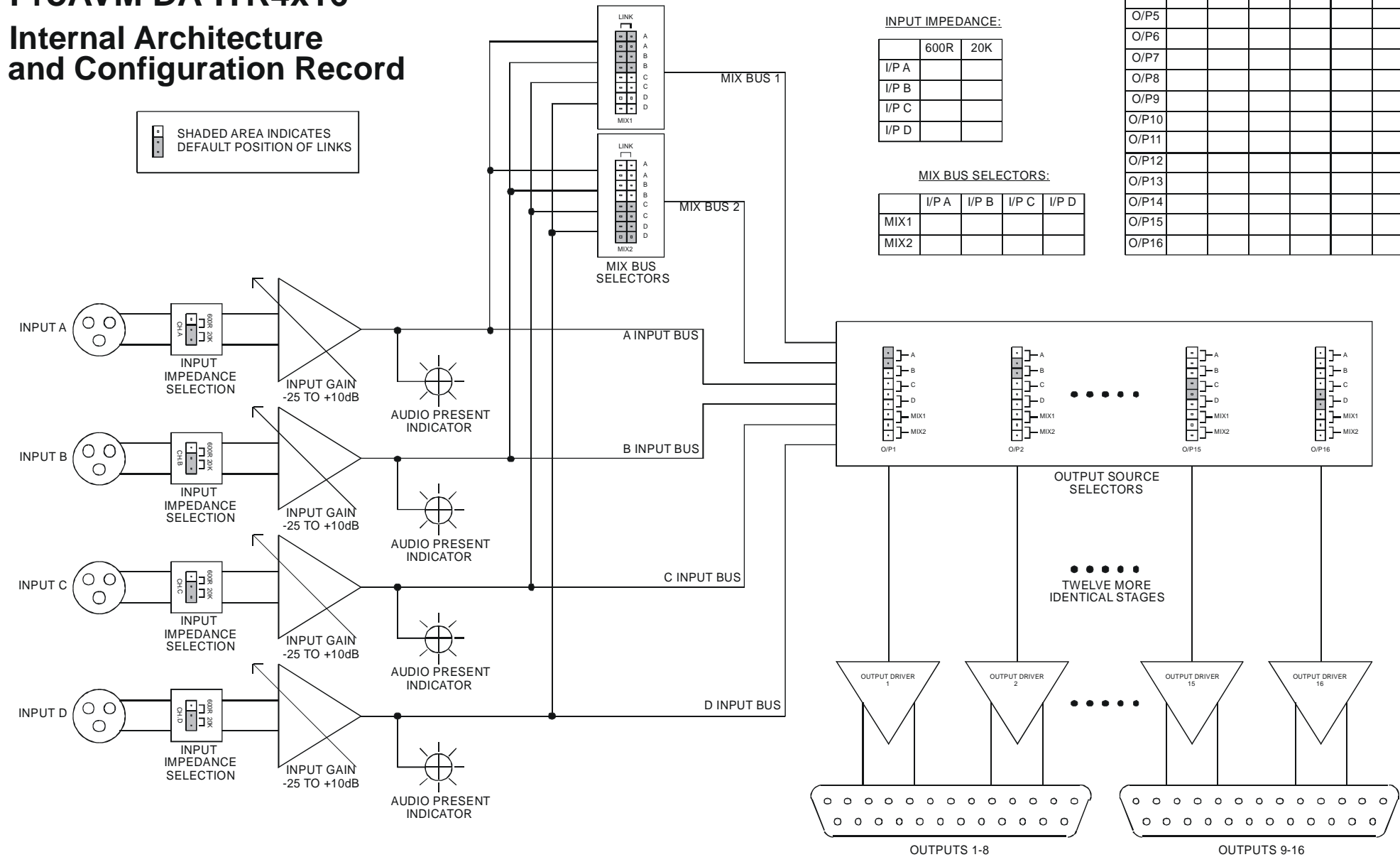

PERSONAL SETTINGS FOR FLEXDA SERIAL NUMBER:

--

INPUT IMPEDANCE:

	600R	20K
I/P A		
I/P B		
I/P C		
I/P D		

MIX BUS SELECTORS:

	I/P A	I/P B	I/P C	I/P D
MIX1				
MIX2				

OUTPUT SOURCE SELECTORS:

	A	B	C	D	MIX1	MIX2
O/P1						
O/P2						
O/P3						
O/P4						
O/P5						
O/P6						
O/P7						
O/P8						
O/P9						
O/P10						
O/P11						
O/P12						
O/P13						
O/P14						
O/P15						
O/P16						